

ශ්‍රී ලංකා විභාග දෙපාර්තමේන්තුව ශ්‍රී ලංකා විභාග දෙපාර්තමේන්තුව ශ්‍රී ලංකා විභාග දෙපාර්තමේන්තුව ශ්‍රී ලංකා විභාග දෙපාර්තමේන්තුව ශ්‍රී ලංකා විභාග දෙපාර්තමේන්තුව
 இலங்கைப் பரீட்சைத் திணைக்களம் இலங்கைப் பரීட்சைத் திணைக்களம் இலங்கைப் பரීட்சைத் திணைக்களம் இலங்கைப் பரීட்சைத் திணைக்களம் இலங்கைப் பரීட்சைத் திணைக்களம்
 Department of Examinations, Sri Lanka Department of Examinations, Sri Lanka Department of Examinations, Sri Lanka Department of Examinations, Sri Lanka Department of Examinations, Sri Lanka
 இலங்கைப் பரීட்சைத் திணைக்களம் இலங்கைப் பரීட்சைத் திணைக்களம் இலங்கைப் பரීட்சைத் திணைக்களம் இலங்கைப் பரīட்சைத் திணைக்களம் இலங்கைப் பரīட்சைத் திணைக்களம்
 Department of Examinations, Sri Lanka Department of Examinations, Sri Lanka Department of Examinations, Sri Lanka Department of Examinations, Sri Lanka Department of Examinations, Sri Lanka

80 E I, II

අධ්‍යයන පොදු සහතික පත්‍ර (සාමාන්‍ය පෙළ) විභාගය, 2018 දෙසැම්බර්
 கல்விப் பொதுத் தராதரப் பத்திர (சாதாரண தர)ப் பரீட்சை, 2018 டிசெம்பர்
 General Certificate of Education (Ord. Level) Examination, December 2018

තොරතුරු හා සන්නිවේදන තාක්ෂණය I, II
 தகவல் தொடர்புடல் தொழினுட்பவியல் I, II
 Information & Communication Technology I, II

07.12.2018 / 0830 - 1140

භූමිකා
 மூன்று மணித்தியாலம்
 Three hours

අමතර කියවීමේ කාලය - මිනිත්තු 10 යි
 மேலதிக வாசிப்பு நேரம் - 10 நிமிடங்கள்
 Additional Reading Time - 10 minutes

Use **additional reading time** to go through the question paper, select the questions and decide on the questions that you give priority in answering.

Information & Communication Technology I

Note :

- Answer *all* questions.
- In each of the questions 1 to 40, pick one of the alternatives (1), (2), (3), (4) which is *correct* or *most appropriate*.
- Mark a cross (X) on the number corresponding to your choice in the answer sheet provided.
- Further instructions are given on the back of the answer sheet. Follow them carefully.

- In which form is data and instructions stored in a computer?
 (1) binary (2) decimal (3) hexadecimal (4) octal
- Which of the following is the octal equivalent of decimal 156_{10} ?
 (1) 121_8 (2) 234_8 (3) 574_8 (4) 770_8
- Which of the following is the binary equivalent of hexadecimal $2B_{16}$?
 (1) 00101011_2 (2) 01001001_2 (3) 10010100_2 (4) 10110011_2
- Which of the following lists 10011001_2 , 113_8 , 160_{10} and $1A_{16}$ in the ascending order?
 (1) 10011001_2 , 113_8 , 160_{10} , $1A_{16}$ (2) 160_{10} , $1A_{16}$, 10011001_2 , 113_8
 (3) 160_{10} , $1A_{16}$, 113_8 , 10011001_2 (4) $1A_{16}$, 113_8 , 10011001_2 , 160_{10}
- In which of the following number systems, is the number '800' a valid number?
 (1) decimal only (2) decimal and hexadecimal only
 (3) decimal and octal only (4) octal only
- Consider the following logic circuit.

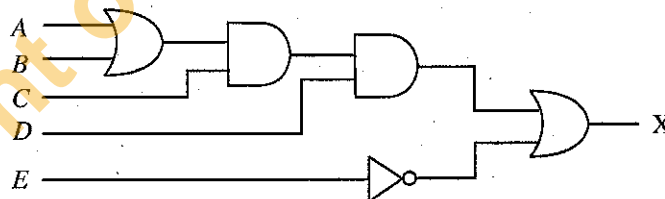

Which of the following is equivalent to the above circuit?

- $X = (A+B) \cdot C \cdot (D+\bar{E})$
- $X = (A+B) \cdot C \cdot D + \bar{E}$
- $X = (A \cdot B) + C + D \cdot \bar{E}$
- $X = (A+B) \cdot (C+D) + E$



7. For given inputs, which of the following logic circuits provide the same output?

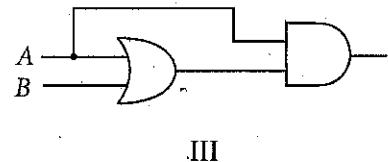
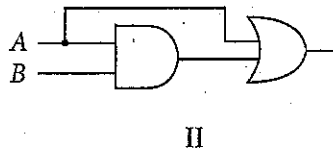
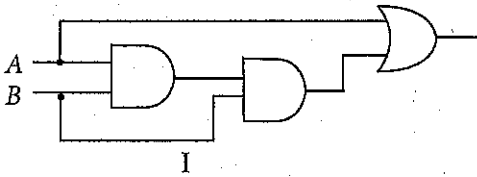

- (1) I and II only (2) I and III only (3) II and III only (4) all I, II and III

8. When a new printer is connected to a computer, installing a special software is usually required for the proper functioning of the printer. What is this special software called?

- (1) defragmenter (2) device driver (3) file manager (4) task manager

9. Which of the following is first activated, when a computer is switched on?

- (1) Basic Input Output System (BIOS) (2) disk partitioning tool
(3) operating system (4) task manager

10. Which of the following can be applied to a blank table in a word processed document?

- A - colouring cells of the table
B - merging adjoining cells in the table
C - inserting cells into the table

- (1) A and B only (2) A and C only (3) B and C only (4) all A, B and C

11. Which of the following tools can be used to find a given term in a word processed document?

- (1) (2) (3) (4)

12. Consider the following steps used in printing invitations to a list of invitees using the mail merge facility of a word processor software.

- A - Create the invitation letter as the[Ⓟ].....
B - Create and save the list of invitees with their addresses as the[Ⓞ].....
C - Use mail merge feature to insert details from the[Ⓞ]..... into the[Ⓟ]..... and print invitations

Which of the following is suitable to fill the blanks labelled [Ⓟ] and [Ⓞ] respectively?

- (1) data source, master document (2) master document, data source
(3) master document, thesaurus (4) thesaurus, master document

• Questions No. 13 and 14 are based on the spreadsheet segment shown below.

Values of y are to be calculated using the equation $y = px^2 + qx + r$ for given values of x . Values for p , q and r constants are given in cells B1, B2 and B3 respectively; values for x are given in the cell range C2:C6.

	A	B	C	D
1	p	2	x	y
2	q	3	-2	
3	r	5	-1	
4			0	
5			1	
6			2	
7				

13. What is the formula that has to be written in cell D2 to get the value of y when $x = -2$?

- (1) = $\$B\$1*\$C2*\$C2+\$B\$2*\$C2+\$B\$3$ (2) = $B1+C2*C2+B2*C2+\$B\3
(3) = $(B1*C2)^2+\$B\$2*\$C2+\$B\$3$ (4) = $\$B\$1*\$C2*\$C2+\$B\$2+C2+\$B\3

14. Assume that you have copied the formula in D2 to cell range D3:D6 to get the other values of y . What is the formula to be written in cell D7 to get the highest value of y ?

- (1) = $AVERAGE(D2:D6)$ (2) = $COUNT(D2:D6)$
(3) = $MAX(D2:D6)$ (4) = $MIN(D2:D6)$

15. What would be displayed if the formula $=(6-2)^2+(5+4)/3$ is entered into a cell in a spreadsheet?
 (1) 5 (2) 8.33 (3) 19 (4) 22.3
16. Which keys in the set {Enter key, Esc key, Space bar} can be used to go to the next slide in the *slide show view* of a presentation?
 (1) Enter key and Space bar only (2) Space bar and Esc key only
 (3) Enter key and Esc key only (4) Enter key and Esc key and Space bar
17. A person inserts his Automatic Teller Machine (ATM) card into a bank ATM and enters the pin code. Then he enters the amount of money he wants to withdraw. After checking the available balance in the account, the ATM dispenses the money, updates the balance and displays the new balance.
 Which of the following, lists an *input*, a *process* and an *output* in the given scenario respectively?
 (1) amount of money to withdraw, new balance, money
 (2) amount of money to withdraw, updating the balance, new balance
 (3) new balance, pin code, amount of money to withdraw
 (4) updating the balance, pin code, new balance
18. Which of the following occurred during the evolution of computer technology from the first generation to the current?
 A - processing power of computers increased
 B - number of transistors per square centimeter in the CPU increased
 C - storage capacity of computers increased
 (1) A and B only (2) A and C only (3) B and C only (4) all A, B and C
19. Which of the following is suitable for durable storage of data in a computer?
 (1) cache memory (2) hard disk (3) RAM (4) video memory
20. Which of the following lists **only** input devices?
 (1) keyboard, barcode reader, CD ROM, flatbed scanner
 (2) keyboard, webcam, touch screen, flatbed scanner
 (3) mouse, keyboard, touch screen, flatbed scanner
 (4) mouse, webcam, touch screen, flatbed scanner
21. Which of the following can be used to measure the clock speed of the Central Processing Unit of a computer?
 (1) Gigabyte (GB) (2) Gigahertz (GHz)
 (3) Megabits per second (Mbps) (4) Revolutions per minute (RPM)

- Questions No. 22 and 23 are based on the following **Books table** used to keep records of books in a library:

Books Table

ISBN	BookID	BookName	PublisherID	Edition
9789556682015	2304	ICT for your life	6	2
9789556682015	2305	ICT for your life	6	2
9789556902015	2306	Database Systems	2	4

22. What is a suitable field for the primary key?
 (1) BookID (2) BookName (3) ISBN (4) PublisherID
23. What is a suitable field for the foreign key?
 (1) BookID (2) BookName (3) Edition (4) PublisherID

[see page four



24. Consider the following two tables named **Marks** and **Subjects**:

Marks Table

Admission_No	Subject_Code	Marks
1111	80	89
1112	33	69
1113	34	72
1111	33	78

Subjects Table

Subject_Code	Subject_Name
80	ICT
33	History
34	Science

Which of the following statements is **incorrect** regarding the **Marks** and **Subjects** tables?

- (1) *Admission_No* and *Subject_Code* in *Marks* table is a composite key.
- (2) *Admission_No* is a primary key in *Marks* table.
- (3) *Subject_Code* is a foreign key in *Marks* table.
- (4) There is a one-to-many relationship between *Subjects* table and *Marks* table.

25. Which of the following is correct regarding a database?

- (1) A collection of fields makes a record; a collection of records makes a table, and a collection of tables makes a database
- (2) A collection of fields makes a table; a collection of tables makes a record, and a collection of records makes a database
- (3) A collection of records makes a field; a collection of fields makes a table, and a collection of tables makes a database
- (4) A collection of tables makes a record; a collection of records makes a field, and a collection of fields makes a database

26. Which of the following lists, shows the most suitable media to transmit data with copper wire, reflection of light and radio waves respectively?

- (1) fiber optics, twisted pair, WiFi
- (2) fiber optics, WiFi, twisted pair
- (3) twisted pair, fiber optics, WiFi
- (4) twisted pair, WiFi, fiber optics

27. If www.google.com website is at the IP address 172.217.27.4, which of the following is used by the web browser to find the IP address of the Google site to send the HTTP request?

- (1) DNS server
- (2) Domain server
- (3) Mail server
- (4) Web server

28. If a person wants to send a 200 MB file to another person through the internet, which of the following methods are suitable?

- A - attach to an email and send it
 B - use FTP service to transfer the file
 C - use an online storage drive such as Google drive and send the link

- (1) A and B only
- (2) A and C only
- (3) B and C only
- (4) All A, B and C

29. Which of the following tools can be used to colour the figure shown on the right in yellow using an image editing software?

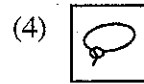
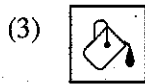
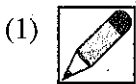

30. Which of the following statements regarding the *waterfall model* relating to Systems Development Life Cycle (SDLC) is/are true?

- A - In this model, activities of each phase are completed before starting the work in the following phase.
 B - This model helps to develop an initial basic system which is developed into a full system in an iterative incremental fashion.
 C - In this model, usually the user sees the system at the initial phases of the system development life cycle.

- (1) A only
- (2) A and B only
- (3) A and C only
- (4) B and C only

[see page five

31. The column on the left below shows four types of system deployment methods labeled (A) - (D) that can be used to make a new system operational. The right side column gives descriptions of four different methods of deployment indicated by labels (P) - (S).

(A) Direct deployment	(P) installs new system to a selected group of users in an organization
(B) Parallel deployment	(Q) installs a new system and makes it operational in a series of steps
(C) Pilot deployment	(R) installs new system, quickly makes the system operational and immediately turns off any overlapping systems
(D) Phased deployment	(S) operates the old and new systems together for a period of time

Which of the following correctly matches the deployment types (A)-(D) with the descriptions (P)-(S)?

- (1) (A) → (Q), (B) → (S), (C) → (P), (D) → (R) (2) (A) → (R), (B) → (P), (C) → (S), (D) → (Q)
 (3) (A) → (R), (B) → (S), (C) → (P), (D) → (Q) (4) (A) → (R), (B) → (S), (C) → (Q), (D) → (P)

32. What is the correct HTML statement for inserting an image?

- (1) (2)
 (3) <image src="image.gif" alt="MyImage"> (4) image.gif

33. Which of the following statements regarding image compression is/are true?

- A - With lossless compression, every single bit of data that was originally in the file remains after the file is uncompressed
 B - Lossy compression is used to reduce data size for storage, handling and transmission
 C - Lossy compression creates larger files size than lossless compression

- (1) A only (2) A and B only (3) A and C only (4) B and C only

34. Which of the following is **not** an example for an e-government service?

- (1) Accessing GCE O/L results from website of the Department of Examinations, Sri Lanka
 (2) Buying items from an online shop
 (3) Downloading National Identity Card application from the Department of Registration of Persons
 (4) Paying water bills online on the website of the National Water Supply and Drainage Board

35. Consider the following pseudocode segment:

```

Payment_option = 'False'
IF distance > 100 THEN
    Payment_option = 'True'
    IF vehicle_type = 'Bus' THEN
        Payment_option = 'False'
    ENDIF
ENDIF
    
```

Which of the following statements is correct according to the above pseudocode?

- (1) If distance = 99 and vehicle_type = 'Car' then Payment_option will be made 'True'.
 (2) If distance = 99 and vehicle_type = 'Bus' then Payment_option will be made 'True'.
 (3) If distance = 101 and vehicle_type = 'Bus' then Payment_option will be made 'False'.
 (4) If distance = 101 and vehicle_type = 'Car' then Payment_option will be made 'False'.

36. Marks obtained by 10 students for the ICT paper is given in the following array A, which has indexing starting at 0.

A:	76	49	54	88	61	68	72	93	37	70
----	----	----	----	----	----	----	----	----	----	----

Which of the following indexed items can be used to retrieve the highest mark?

- (1) A [0] (2) A [1] (3) A [7] (4) A [9]

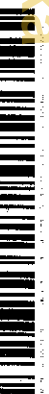

37. How many times will the \$ mark be displayed after the execution of the following pseudocode?

```

BEGIN
  P = 0
  REPEAT
    Q = P MOD 2
    IF Q = 1 THEN
      DISPLAY '$'
    ENDIF
    P = P + 1
  UNTIL P < 5
END
    
```

- (1) 1 (2) 2 (3) 3 (4) 4

38. Consider the flowchart on the right which inputs a number and displays the message 'Valid Mark' if the input number is between 0 and 100.

What should be the correct terms for labels P, Q and R respectively?

- (1) $N \leq 100$, No, Yes
 (2) $N \leq 100$, Yes, No
 (3) $N = 100$, No, Yes
 (4) $N = 100$, Yes, No

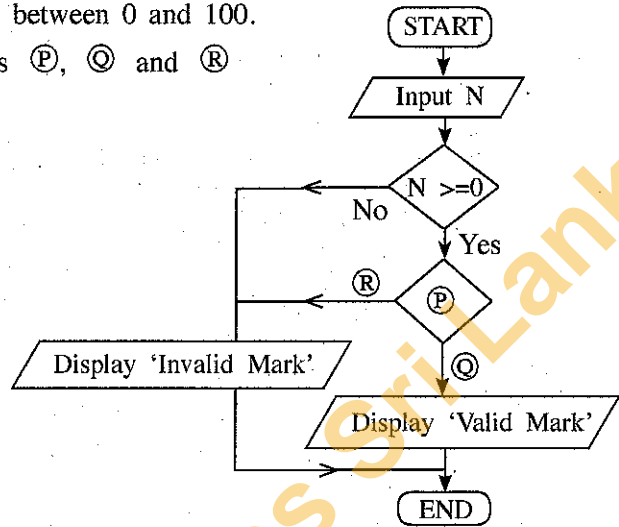

39. Which of the pseudocodes is equivalent to the logic of the flowchart on the right?

- (1) BEGIN
 READ C
 $F = 9 * C$
 $F = F + 32$
 $F = 5 * F$
 SHOW F
 END
- (2) BEGIN
 READ C
 $3F = 9 * C / 5 + 32$
 SHOW F
 END
- (3) BEGIN
 READ C
 $F = 9 * C / 5 + 32$
 SHOW F
 END
- (4) BEGIN
 READ C
 $F = 9 * C$
 $F = C + 32$
 $F = 5 * C$
 SHOW F
 END

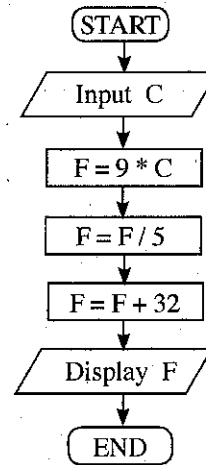

40. Which of the following is/are correct regarding programming languages?

- A - Machine language uses binary digits (bits) based instructions which a computer can understand.
- B - Assembly is a low level machine dependent programming language which uses a symbolic representation of machine code.
- C - High level programming languages are machine independent.

- (1) A only (2) A and C only (3) B and C only (4) All A, B and C

* *

[see page seven

ශ්‍රී ලංකා විභාග දෙපාර්තමේන්තුව ශ්‍රී ලංකා විභාග දෙපාර්තමේන්තුව ශ්‍රී ලංකා විභාග දෙපාර්තමේන්තුව ශ්‍රී ලංකා විභාග දෙපාර්තමේන්තුව ශ්‍රී ලංකා විභාග දෙපාර්තමේන්තුව
 இலங்கைப் பரீட்சைத் திணைக்களம் இலங்கைப் பரීட்சைத் திணைக்களம் இலங்கைப் பரීட்சைத் திணைக்களம் இலங்கைப் பரීட்சைத் திணைக்களம் இலங்கைப் பரීட்சைத் திணைக்களம்
 Department of Examinations, Sri Lanka Department of Examinations, Sri Lanka Department of Examinations, Sri Lanka Department of Examinations, Sri Lanka Department of Examinations, Sri Lanka
 இலங்கைப் பரීட்சைத் திணைக்களம் இலங்கைப் பரීட்சைத் திணைக்களம் இலங்கைப் பரීட்சைத் திணைக்களம் இலங்கைப் பரīட்சைத் திணைக்களம் இலங்கைப் பரīட்சைத் திணைக்களம்
 Department of Examinations, Sri Lanka Department of Examinations, Sri Lanka Department of Examinations, Sri Lanka Department of Examinations, Sri Lanka Department of Examinations, Sri Lanka

80 E I, II

අධ්‍යයන පොදු සහතික පත්‍ර (සාමාන්‍ය පෙළ) විභාගය, 2018 දෙසැම්බර්
கல்விப் பொதுத் தராதரப் பத்திர (சாதாரண தர)ப் பரீட்சை, 2018 டிசெம்பர்
General Certificate of Education (Ord. Level) Examination, December 2018

කොරකුරු හා සන්නිවේදන තාක්ෂණය I, II
 தகவல் தொடர்பாடல் தொழினுட்பவியல் I, II
Information & Communication Technology I, II

Information & Communication Technology II

* Answer five (05) questions only, including the first question and four others.
 * First question carries 20 marks and each of the other questions carries 10 marks.

- (i) If character 'm' is represented in the ASCII table as 109₁₀ write down the binary representation of the word 'no' using 7 bits for each character.
- (ii) (a) Consider the following simplified logic circuit, which is designed to switch on a ceiling fan when temperature is HIGH while the power switch is ON. Write down the two relevant logic gates for P and Q.

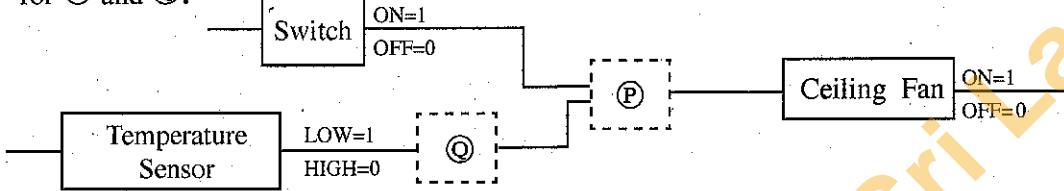

- (b) Consider the following simplified circuit of a washing machine:

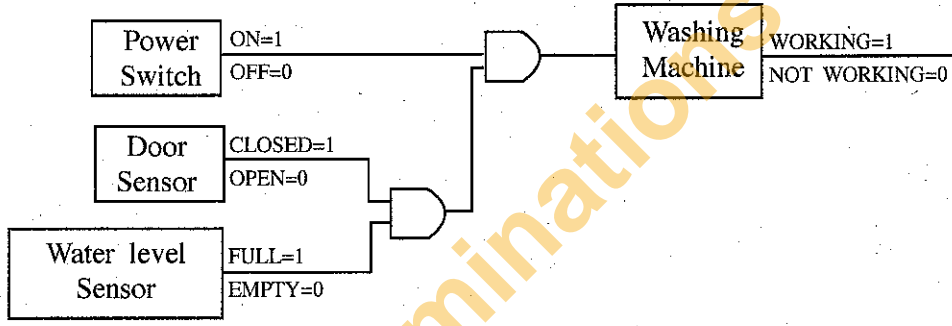

The following is the truth table equivalent to the above logic circuit. Write down labels (A - H) and the corresponding truth value (1,0) of each label.

Power switch	Door sensor	Water level sensor	Washing machine
OFF (0)	OPEN (0)	EMPTY (0)(A).....
OFF (0)	OPEN (0)	FULL (1)(B).....
OFF (0)	CLOSED (1)	EMPTY (0)(C).....
OFF (0)	CLOSED (1)	FULL (1)(D).....
ON (1)	OPEN (0)	EMPTY (0)(E).....
ON (1)	OPEN (0)	FULL (1)(F).....
ON (1)	CLOSED (1)	EMPTY (0)(G).....
ON (1)	CLOSED (1)	FULL (1)(H).....

017770





01040000580112770



Department of Examinations Sri Lanka

- (iii) (a) What is the main difference between *waterfall life cycle model* and *iterative incremental life cycle model*?
 (b) List **one** advantage of *iterative incremental life cycle model*.
- (iv) Assume that a desktop computer was purchased and you are asked to connect different peripheral devices to it. **Tasks** column shown below lists the tasks to be carried out for this purpose and the **Port** column shows ports or connectors to be used. Match each task to the relevant port and write down the task number and the matching port label.

Task
Task 1 – <i>Connect the LED display to the system unit</i>
Task 2 – <i>Connect keyboard and the mouse</i>
Task 3 – <i>Connect network cable</i>
Task 4 – <i>Connect the power cable</i>

Port
(A) – 
(B) – 
(C) – 
(D) – 

- (v) Consider the following phrase before and after formatting using word processing software:
 (Assume that the font size of the phrase has not been changed.)

Before formatting : Essential 21st Century Skills for Today's Students

After formatting : *Essential 21st Century Skills for Today's Students*

Write down the word processing software tools required for the above formatting.

- (vi) The column on the left lists three types of cloud computing services (labeled (A)-(C)) and the column on the right describes some of the services provided by each (labeled (X)-(Z)). Match items in the two columns and write down the corresponding pairs using their labels.

(A) – Infrastructure as a service (IaaS)	(X) – Provides software installed in the cloud [Example: <i>Google Docs</i>]
(B) – Software as a Service (SaaS)	(Y) – Provides necessary server environment for software development [Example: <i>Google App Engine</i>]
(C) – Platform as a Service (PaaS)	(Z) – Provides facilities such as servers, network, storage, etc. [Example: <i>Amazon Web Services (AWS)</i>]

- (vii) Following gives four different scenarios labelled (S1) – (S4) that require different communication methods:

- (S1) - A manager of a bank, while in Sri Lanka, joining a meeting held in their Head Office in India
- (S2) - A secretary sending a softcopy of a report from her manager to all employees working in a different city
- (S3) - A technical officer sending a message to his manager informing that the machine has been repaired
- (S4) - A marketing manager sharing photos of a community service project and obtaining feedback from customers as comments

Identify the **most suitable** communication method for each of the above scenarios from the list given below and write down label number and communication method.

List : {*blog, email, instant messaging, social network, video conferencing*}

- (viii) How many different colours can be represented if 10 bits per pixel (bpp) is used as *colour depth* in an image?
- (ix) Consider the given flowchart that finds the product of an integer with all the integers below it.
 (E.g. : If N is the given integer then the product = $1 \times 2 \times 3 \dots \times N$)
 Ⓐ and Ⓑ are expressions to be completed.

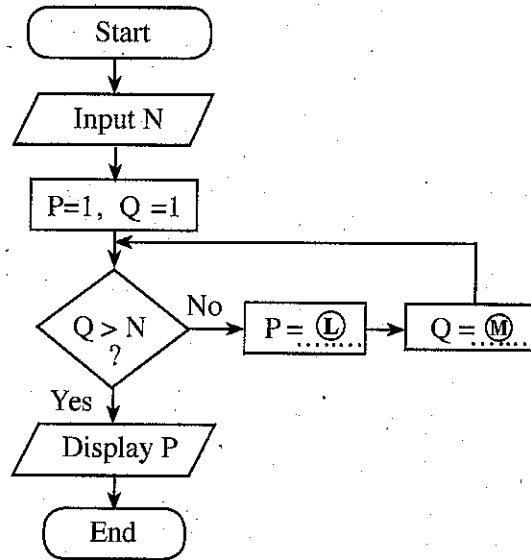

- (a) Write the correct expressions for Ⓐ and Ⓑ, respectively.
 (b) If $N = 4$, write down the final values of P and Q when the algorithm reaches the end.

(x) Consider the **Employee** and **Division** tables given below:

Emp_Name	Emp_ID	Designation	Div_ID
Saman Perera	E1	Manager	Ⓐ
Raj Selvam	E2	Engineer	Ⓑ
John Allison	E3	ICT Officer	Ⓒ
Fazal Khan	E4	Accountant	Ⓓ

Employee table

Division_Name	Division_Number	Division_Location
Finance	1	Colombo 1
Stores	2	Colombo 2
Sales	3	Colombo 3

Division table

- (a) Assume that a new division named *IT* located in *Colombo 3* is to be added. Write down the new record that has to be added and the corresponding table name.
 (b) Saman and John work at *Stores*. Fazal works at *Finance Division*. Raj recently joined the *IT Division*. Write down the correct values for labels Ⓐ - Ⓓ in **Employee** table to represent this information.

2. (i) People who work with computers for long periods sometimes complain of certain health issues. The following shows the **Health Issues** (labeled A - C), **Possible Reasons** (labeled G - I) and **Possible Solutions** (labeled P - W).

Match each health issue A - C, with a possible reason G - I and a possible solution P - W and write down using their labels.

(Note: There can be more than one possible solution for a given health issue. However, you are required to write only one solution.)

Health Issue
A - Carpel Tunnel Syndrome
B - Computer Vision Syndrome (Digital Eye Strain)
C - Musculoskeletal disorder

Possible Reason
G - Poor posture or a non-ergonomically designed work space
H - Painful compression of a nerve as it passes across the front of the wrist.
I - Looking at computer screen for prolonged periods

Possible Solutions

- P - Rest the eye muscles by looking up and staring for a moment at objects in the distance
- Q - Stand up and stretch the back, arms and fingers frequently
- R - Take regular short breaks from a repetitive task by using an alarm as a reminder
- S - Avoid bending the wrists and keep the arms, wrists and fingers aligned when typing
- T - Use keyboard shortcuts to reduce typing and mouse movements
- U - Avoid hitting the keys too hard while typing / use *touch typing*
- V - Position the computer screen to avoid glare / use curtains or drapes on windows
- W - Keep the computer screen about 15 to 20 degrees below eye level

- (ii) For each of the issues (labelled A-D) below, identify the relevant term from the list and write down the term against each relevant label.

- A - A person receiving an email that appears to have come from a well-known organization and asking for personal information such as the credit card number, the user name and the password of the person's online banking facility
- B - The practice of taking someone else's work and publishing them off as one's own
- C - A person having unauthorized access to a computer network and accessing personal information such as names and addresses of customers
- D - A person selling unauthorized copies of a licensed software at a 5% of the original price

List of terms : {fair use, forgery, hacking, phishing, plagiarism, piracy, spam}

3. (i) The HTML source of the web page shown in **Figure 1** is given in **Figure 2** with certain missing tags and parameters labelled ① - ⑧.

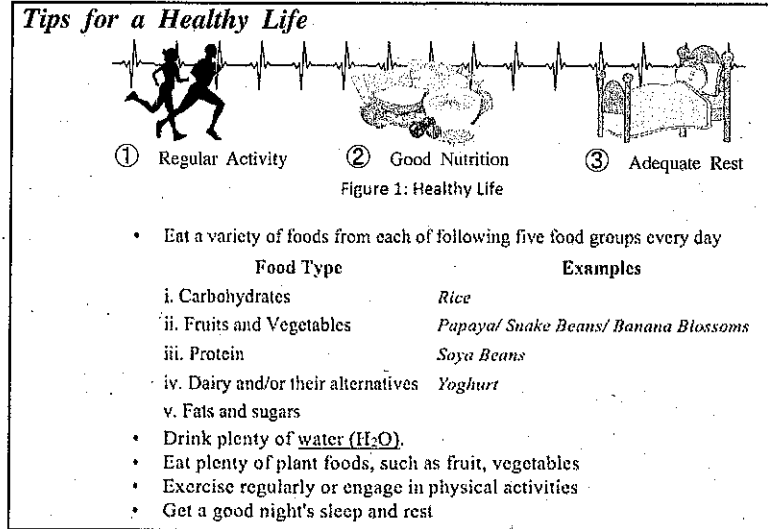

Figure 1 web page

```

<!DOCTYPE html>
<html>
<body>
<h2><①>Tips for a Healthy Life</①></h2>
<②><img ③="health.jpg" ④="Healthy Life" width="460" height="345"></②>
<p><②> Figure 1: Healthy Life</②></p>
<⑤>
<li>Eat a variety of foods from each of following five food groups every day</li>
<⑥>
<tr>
<th>Food Type</th>
<th>Examples</th>
<tr>
<td>i. Carbohydrates</td>
<td><i>Rice</i></td>
<tr>
<td>ii. Fruits and Vegetables</td>
<td><i>Papaya/ Snake Beans/ Banana Blossoms</i></td>
<tr>
<td>iii. Protein</td>
<td><i>Soya Beans</i></td>
<tr>
<td>iv. Dairy and/or their alternatives</td>
<td><i>Yoghurt</i></td>
<tr>
<td>v. Fats and sugars</td>
<tr>
<li>Drink plenty of <⑦ href="https://www.purewaterfortheworld.org">water
(H<⑧>2</⑧>O)</⑦>.</li>
<li>Eat plenty of plant foods, such as fruit, vegetables</li>
<li>Exercise regularly or engage in physical activities</li>
<li>Get a good night's sleep and rest</li>
</⑤>
</body>
</html>
    
```

Figure 2 The HTML Source code

Select the matching correct tag or parameter from the following list for each of the labels ① - ⑧ given in **Figure 2** and write down against each label number.

List of terms : {a, alt, b, br, center, dl, href, i, img, li, ol, p, src, sub, sup, table, td, th, tr, ul}

[see page twelve

(ii) Use the following list of terms in answering questions (a) and (b) below.

List of terms : { DNS server, domain name, FTP, IP address, mail server, path to resource, protocol, resource, SMTP, spam mail, streaming server, top level domain, uniform resource locator (URL), web server, World Wide Web (WWW) }

(a) Identify the correct term from the above list for labels (P) - (V) below and write the correct terms against the label.

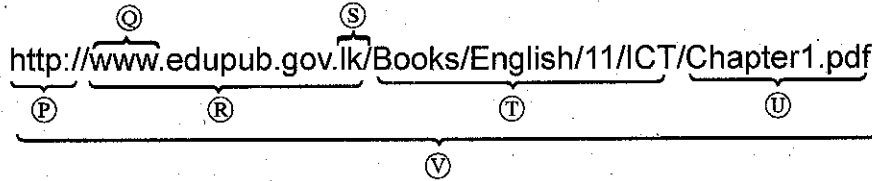

(b) Match the descriptions given in (A) - (D) with the correct terms from the list given above and write down the relevant term against the label.

(A)	Delivers web pages to clients using HTTP
(B)	Helps uniquely identify a computer on the internet
(C)	Every email that is sent passes through a series of this type of servers along its way to its intended recipient
(D)	Unwanted email messages

4. (i) Consider the spreadsheet segment given below containing prices of two models of laptop computers and their accessories.

	A	B	C
1	Description	Price (Rs.)	
2		Model A	Model B
3	Laptop computer	64000	71000
4	Bag	1500	1750
5	Mouse device	450	500
6	Total	65950	
7	Total including delivery Cost	66300	73600
8			
9			
10	Delivery Charge (City limits)	350	
11			

The delivery cost is Rs. 350 and this cost is shown in cell B10. "Total" and "Total including Delivery Cost" are to be calculated for the two models.

- (a) Write down the formula that should be entered in cell B6 to calculate the 'Total' for Model A in the form of =function(cell1:cell2).
- (b) If this formula is copied to cell C6, what value will be displayed in C6?
- (c) Write down **two** formulae that can be written in cell B7 to calculate the "Total including Delivery Cost" using **only** cell addresses, functions and arithmetic operators.
- (d) If the formula in cell B7 was copied to cell C7, and value shown in C7 was 73600, what formula is in cell C7?

(ii) (a) Consider the presentation software slide layouts shown as (A) - (D) :

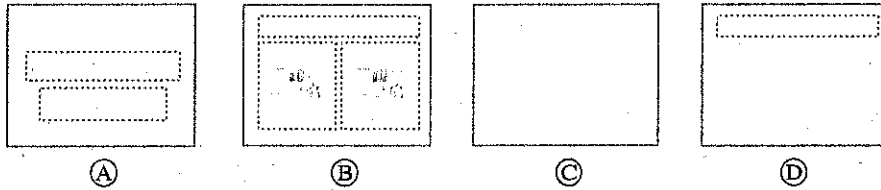

Identify the correct name of each layout from the list of names given below and write it down against the layout label.

List: {Title slide, Blank slide, Title & content slide, Title only slide, Section header slide, Two Content slide}

(b) Which of the following views is the most suitable to arrange the positioning of slides?

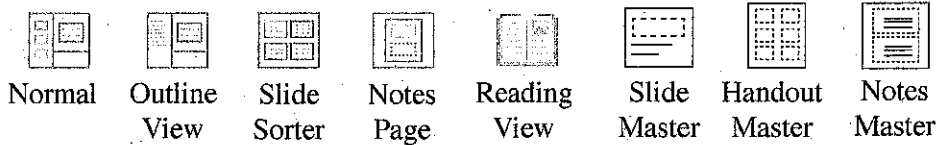

5. Assume that the following is a part of the relational database of a business information system. This business has shops in certain schools in different parts of the country.

Month	ShopID	Sales
January	001	12400
March	001	18700
December	003	15330
February	001	11230
March	002	16330

Sales Table

Category	Items
A	Ice Cream & Milk
B	Milk
C	Milk & Stationery

Category Table

Name	ShopID	Category
ABC College	001	A
PQR Central College	002	B
XYZ College	003	C

Branch Table

- (i) Write down **two** primary keys and their respective table names.
- (ii) Write down **two** foreign keys and their respective table names.
- (iii) What table should be modified to include the telephone number of each shop?
- (iv) Which tables should be joined to run a query to find out the total sales at ABC College?
- (v) Assume that a new shop with ShopID 004 selling Milk & Photocopying services is opened at HIJ College. What tables need to be updated to include the given information?
- (vi) Write down the newly added records as specified in (v) above along with the respective table names.

6. (i) A team who participated in developing a school management system, listed **some** of the activities they carried out with respect to it as Ⓐ - Ⓔ below. The phases of the system development life cycle that was used are labelled from Ⓟ to Ⓤ.

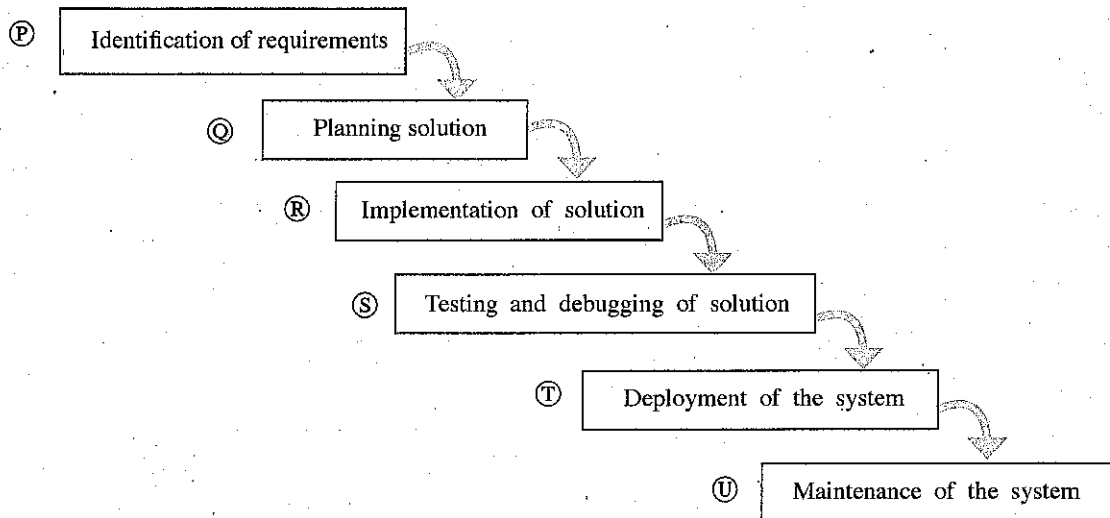

Activities:

- Ⓐ - Using the existing manual system and the newly developed system in parallel for three months; Discontinuing the manual system at the end of the third month
- Ⓑ - Converting the designs of processes, database model and user interfaces etc. into software programs
- Ⓒ - Meeting the principal, teachers, librarian and others to identify the current processes
- Ⓓ - Collecting samples of term test mark sheets, library catalogue, lending cards, daily attendance sheets etc.
- Ⓔ - Interviewing the principal, librarian and sectional head teachers to understand their expectations of the new system and the current problems they face
- Ⓟ - Rewriting parts of code to accommodate a change requested by the principal after using the new system for one year
- Ⓠ - Debugging the system due to an error being pointed out by the librarian after six months of new system usage

- (a) Identify what activities in Ⓐ - Ⓔ are relevant to the life cycle phases Ⓟ - Ⓤ and write down the matching pairs.
- (b) List **three** employment opportunities in the ICT field.

- (ii) The following three statements labelled Ⓧ, Ⓨ and Ⓩ, describe three types of software testing:

- Ⓧ - Individual components of software are tested separately to check if they function properly by producing correct output for the given inputs.
- Ⓨ - End users test the system to evaluate whether the system is suitable for use.
- Ⓩ - Individual components of the software are combined and tested to see if they work together properly.

Identify the correct test types from the following list and write them down against the labels (Ⓧ - Ⓩ).

List of terms : {acceptance testing, integration testing, system testing, unit testing}

7. The following flowchart uses the rule that the sum of any two lengths must be greater than the remaining length in a triangle. Assume that AB, BC and AC are the lengths of a triangle.

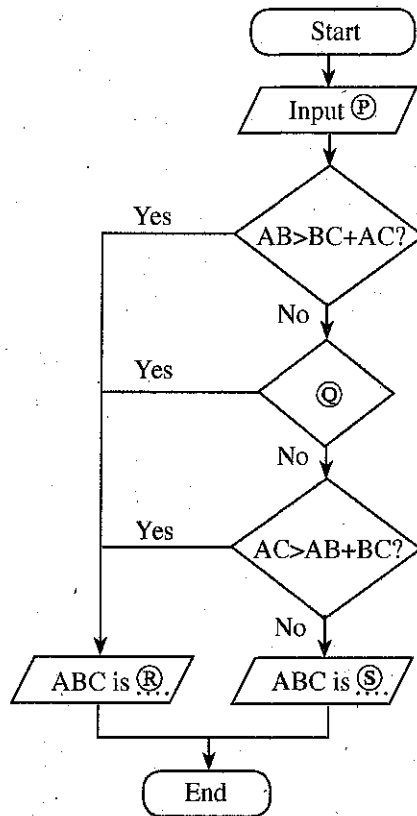

- (i) Write down the correct expressions for missing labels P, Q, R and S in the flowchart.
- (ii) If the three decision boxes in the flowchart are combined into a **single** decision box, write down the expression that should be used in that single decision box.
- (iii) Write pseudocode representing the logic of the updated flowchart, including the changes that were done in (i) and (ii) above.
- (iv) When one or more of the input lengths become zero, this algorithm fails to function properly. Write the pseudocode condition that has to be introduced in between the input and the first decision box in the **original** flowchart to fix this problem.

* * *

Department of Examinations Sri Lanka

Department of Examinations Sri Lanka

0005848